

XYBIX SYSTEMS, INC.

Dispatch Console Product Manual & Trouble Shooting Guide



This page is intentionally left blank

XYBIX SYSTEMS INC.

Dispatch Console Product Manual & Trouble Shooting Guide

Xybix Systems, Inc.
8207 SouthPark Circle
Littleton, CO 80120
Phone: 800.788.2810 • Fax: 303.683.5454
www.xybix.com



Dear Customer,

Thank you for purchasing Xybix Systems! We look forward to helping you make your working environment a success.

Xybix is a family owned business based out of Littleton, Colorado. Xybix ergonomic furniture has been an experienced manufacturer of height-adjustable ergonomic furniture since 1991. Our user-friendly, highly-customizable workspaces help employees get into their productivity zone and stay there.

Xybix has earned itself an enviable reputation as the industry leader in manufacturing ergonomic furniture for 24/7 mission critical environments. We are dedicated to providing our customers with the highest standard of ergonomics and service.

Our expertise in design and ergonomics combined with your company's processes and functionality requirements unite to create a state of the art work station that empowers your company by aligning form and functionality for better health and overall performance.

Our consultative approach ensures customers get the right solution and that each individual get the most benefits of health and productivity available through the proper fit and adjustment.

The attached "Product Manual & Trouble Shooting Guide" will help you easily identify and troubleshoot all areas of importance to assure the smooth performance of your new console furniture.

Please review the following document carefully and contact us if you have any questions. Xybix looks forward to a long and mutually rewarding working relationship with your company.

Sincerely,

Barry R. Carson
President

Table of Contents

6.....Initial Steps

- 6.....Warranty Information
- 7.....Safety Instructions
- 7.....Console Maintenance
- 8.....Customer Receiving Responsibilities

9.....Console

- 9.....Welcome to your console
- 9.....A General Overview

9.....Console Features

- 10.....MyClimate
- 10.....Personal Heater
- 11.....Task Lighting
- 12.....Bias Lighting
- 13.....Rollervision®
- 14.....DataDock
- 15.....Hand Controls (surface)
- 16.....IFit®

17.....MyClimate Controls

- 17.....AirSpeed
- 18.....Filter Maintenance
- 18.....Heat Control
- 18.....Lighting Adjustment

19.....Console Operation

- 20.....Console Movement
- 21.....Console Obstruction
- 22.....Power Bar/Energy Chain

Trouble Shooting Guide

23.....A More In-Depth View of your Console & Components

24.....Operations Trouble Shooting

- 24.....Hand Control (T4, T5 and T6+ Tables)
- 25.....Common Error Codes
- 26-28.....Console Trouble Shooting Guide (T4, T5 and T6+ Tables)

- 29.....Hand Control (T2, T3 Tables)
- 30.....Console Trouble Shooting Guide (T2, T3 Tables)

Initial Steps

Warranty Information, Safety Procedures, Receiving Responsibilities

Xybix is dedicated to helping you achieve your project goals. This manual and guide is to be used as an aide to help users identify the parts, features and types of consoles available to Xybix customers. Should further questions arise that cannot be addressed by this manual, please contact our Customer Service professionals. They are ready to help!

Warranty Information

Xybix Dispatch Console Limited Warranty Information

Warranty Terms and Conditions

Defects in Xybix manufactured products and components covered by this warranty and found during the applicable warranty period (see below) will be repaired or replaced (at Xybix's sole option) upon prompt notice from the original buyer. Troubleshooting tasks (as outlined in the Buyer's responsibility clause below) must be performed before product repair or replacement will be provided. Repairs, substitute products or replacements of equal or higher value used to resolve a warranty claim will in no way extend the applicable warranty period applied to the original product. Xybix will assume responsibility for all shipping and return shipping expenses of any defective product covered by this warranty.

This warranty does not apply to:

- Normal wear and tear and consumable items such as light bulbs
- Xybix products which have undergone unauthorized modifications or reconfiguration
- Products subject to improper use or conditions including negligence, accident or alterations
- Products damaged by AC power disturbances
- Any account not paid in full
- Matching of color, grain or texture

WARRANTY PERIOD

Limited Lifetime Warranty

Except as listed below, any defective Xybix manufactured components will be replaced at no charge for as long as the original purchaser owns the product. Labor and all associated expenses for defective products covered by this warranty will be provided to the original buyer for five years from the date of acceptance or beneficial usage whichever occurs first. This warranty includes parts, labor and shipping costs.

Limited Term Warranty

Lift columns, electronic controls, switches, heating devices and all moving parts found to be defective, will be replaced or repaired (at Xybix's option) for the first six years of original ownership.

BUYER'S RESPONSIBILITY

The execution of this warranty requires the cooperation of the buyer with Xybix. The buyer agrees to perform basic troubleshooting tasks to determine the nature of the defect (and quickly self correct – if possible) with assistance from Xybix customer service before Xybix personnel will provide on-site assistance. In the event that Xybix personnel must provide on-site assistance and the product failure or defect is found to have resulted from items to which this warranty does not apply, the buyer agrees to reimburse Xybix for all expenses resulting from the warranty claim. Expenses include, but are not limited to: product, shipping, installation, transportation and accommodations. An hourly labor rate will be applied for work performed. Xybix makes no other express or implied warranties to any product except as stated above, and in particular, makes no warranty or claim of merchantability or fitness for a particular purpose. Product repair or replacement is the buyer's exclusive remedy for any and all product defects except as outlined in the foregoing warranty.

*Additional Safety Note
As with any moving object, failure to operate according to instructions may cause hazardous situations for persons and equipment!*

Safety Instructions

At Xybix, the safety of our customers and installers is a top priority. Please follow all safety instructions under all circumstances.

- Opening and service of electronic components must be carried out by trained personnel only.
- If product malfunctions i.e. the development of smoke, odors or unusual noises, all system components need to be turned off and all tables connected or power cables need to be disconnected.
- The duty cycle printed on the control box plate may not be exceeded.
- Power cables must not be exposed to pinching, bending to less than 2" radius, or tensile stress.
- Modification of the control box or the hand control is not recommended and will void any warranty.
- Xybix tables are not to be operated in an explosive atmosphere!
- When operating tables, the operator must watch to ensure the table will not come into contact with other objects (i.e. chairs, bins, etc).
- ALWAYS disconnect the power cables before plugging and unplugging the motor and hand control cables.

Console Maintenance and Procedures

- In case of a malfunction, contact **Customer Service at: 800.788.2810**, so we can better serve you. Please try to identify the components, part numbers and gather as much information regarding the problem as possible.
- In the case a part needs to be exchanged, we will ship it at no cost while you are still under warranty; however, to avoid being charged for the replacement components, please return the old ones to us within 30 days. You will find a return label inside the box where the new part is ready for use.
- When the replacement part has arrived to your office, please call to let us know. We will either show you how to properly exchange the pieces or we will schedule a time for one of our installers to go in and repair it for you.

Customer Receiving Responsibilities

Very few items we ship every year are damaged; however, occasional damage does occur. If there is a problem with a shipment, it will save all parties time and money if these procedures are followed carefully, as many items shipped are heavy and are shipped by common carrier (truck). Your help is greatly appreciated.

DO NOT LET THE TRUCK DRIVER INTIMIDATE YOU OR PREVENT YOU FROM CHECKING FOR HIDDEN DAMAGE. IF THEY TRY TO DO THIS, CALL US (303.683.5656) ON THE PHONE AND PUT THE DRIVER ON THE PHONE LINE.

PLEASE NOTE: THE DISCOVERY OF HIDDEN DAMAGE IS YOUR RESPONSIBILITY AND MUST BE DONE AT THE TIME OF DELIVERY!

OPEN the shipment and **INSPECT** the shipment while the truck driver is there. Check for hidden damage regardless of whether or not the shipment appears in good condition. If you do not check for hidden damage and mark it on the bill of lading, you will be responsible for any damage.

IT IS YOUR RESPONSIBILITY TO BE AT THE DELIVERY LOCATION OR HAVE SOMEONE THERE TO UNLOAD AND SIGN FOR THE SHIPMENT AT THE TIME THE TRUCKING COMPANY SAYS THEY WILL BE THERE. IF THERE IS VISIBLE DAMAGE, DO NOT UNLOAD THE SHIPMENT WITHOUT CALLING XYBIX FIRST.

Open all boxes and containers and let us know the extent of any damage. If a part needs to be replaced we may have you keep the shipment and replace the part at your option.* *You may be instructed to refuse severely damaged items, and make note of damage on the bill of lading.*

While most truck drivers are helpful and will try to accommodate you, again remember, that they do not have to help you unload the freight unless you have paid for and made previous arrangements for a lift gate. They have to be courteous and allow you to inspect the merchandise. You can be courteous to them by unloading the shipment in a timely manner.

While shipping damage is never the consignee's (customer's fault), we request that you allow us to offer a reasonable solution on minor damage as opposed to complete product replacement or refund as most items are shipped by truck with a large freight cost. If there is hidden damage and you sign for and accept the shipment, describe the damage in detail and write it on the bill of lading.

If the item has major damage and cannot be repaired, and/or it has been damaged severely and you do not want it repaired and you simply want a new product, refuse the item and we will ship you out a new product. If an item is refused because of damage, make the truck driver note the specific damage on the bill of lading, just as you would if you had accepted it. If you are refusing the item, again, make sure you do so before it is unloaded from the truck and before the trucking company leaves. If a shipment is unloaded and you decide to return it for any reason, then you will be responsible for return shipping cost.

If you are refusing a shipment because of damage, call Xybix at 800.788.2810 while the trucking company is there, and ask for someone that can help you with a freight claim on an order you just received from us. We will assist you before the truck leaves, in case we need any additional information.

Welcome to your Console

A General Overview – Console Features, Helpful Hints, Console Operation

Our consoles are the perfect furniture for use in public safety/911 dispatch centers, help desk call centers and virtually any venue where 24/7 mission critical operations are conducted. Numerous studies have shown that an employee operating within a comfortable, safe and low stress environment will have the capacity to reach a much higher level of productivity and yield greater quality output. Let's review some of the product features on your console.

Console Features

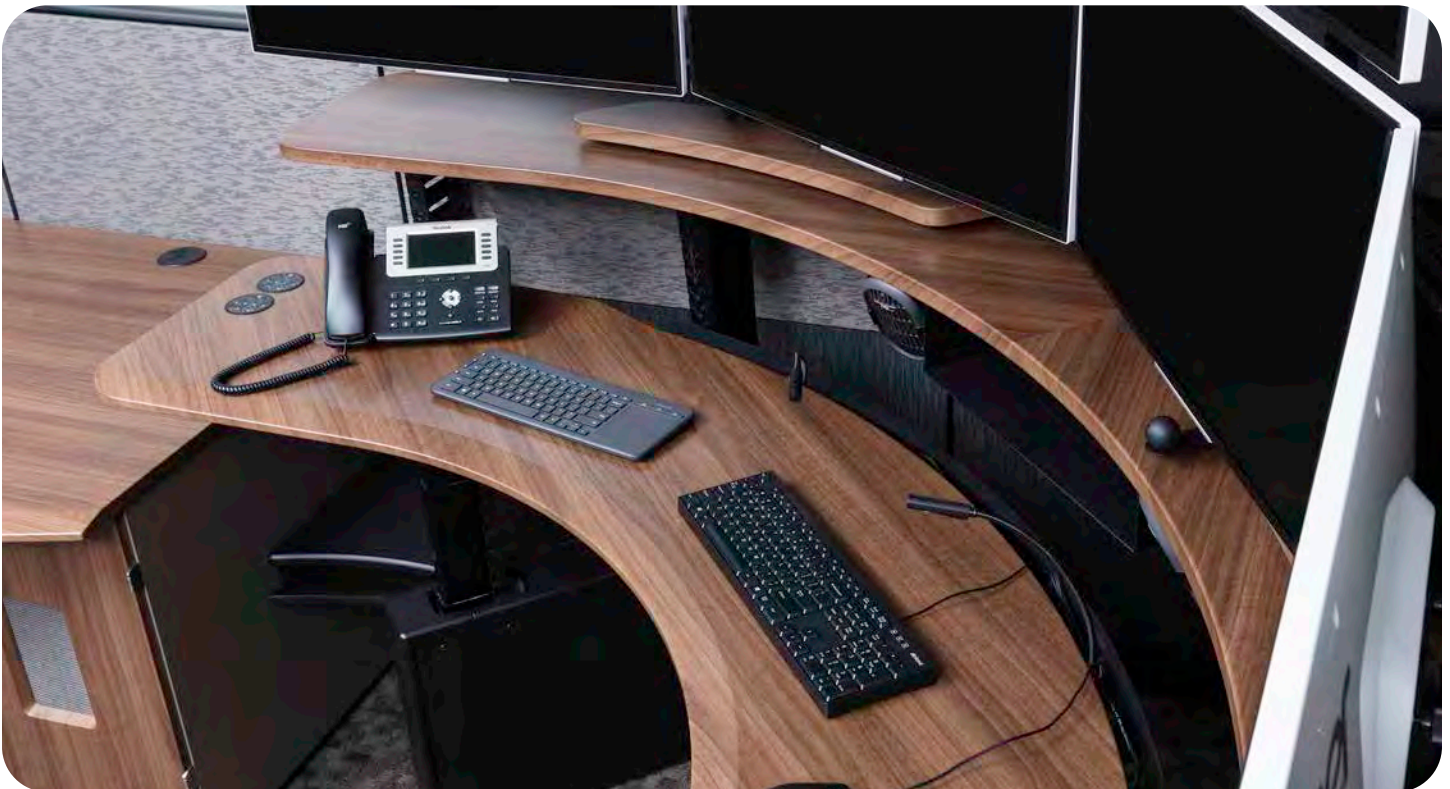

In the following section, we will be discussing common features found on Xybix's furniture. Although some features are optional and may not be found on your particular console. The features discussed will include:

- MyClimate (optional)
- Heaters (optional)
- Lighting (optional)
- Rollervision
- DataDock (optional)
- Hand Control (surfaces)

My Climate

Optional MyClimate feature is a user friendly personal climate control located on top of the front work surface. This controller is an energy saving motion detector. It will turn all functions "off" if there is no presence for 15 minutes, resumes when occupant returns. As indicated on the reverse side of the control, users can adjust their fan speed, dim one or both lights, turn "on/off" the status Indicator light and turn "on/off" the heater.



Personal Heaters

The personal heater feature will be located under your console, just beneath the rear surface, on either side of the under worksurface metal shelf. The "On/Off" switch will be located on the MyClimate controller. Each heater is 250W and requires 4.2Amps.

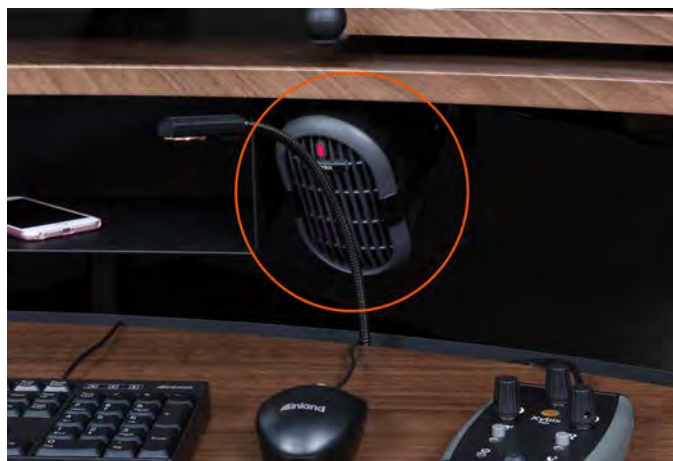



Task Lighting

LED Task Light

- Paired with the Xybix MyClimate control system, task lighting can be dimmed, brightened and turned “on/off” with the MyClimate hand controller.
- Lighting (comes in a pair) attaches to front keyboard surface for a secure mount.
- Energy saving motion detector in MyClimate controller, turns “off” the lighting if no presence is detected for more than 15 minutes.
- LED light cool to touch.
- Stylish and low-profile for an updated and modern look.

Task Lighting

Z-Bar LED Task Light

- The Z-Bar LED Desk Lamp is a compact space-saving design with maximum adjustability.
- Providing over 15,000 hours of illumination, this slim LED lamp provides the equivalent of 30-40 watt incandescent bulb.
- Paired with the Xybix MyClimate control system, task lighting can be dimmed, brightened and turned "on/off" with the MyClimate hand controller.



Bias Lighting

- Reduces or eliminates eye strain and fatigue in dark viewing conditions.
- Eliminates image contamination from conventional room lighting.
- Enhances perceived black levels, contrast ratio, and picture detail. Preserves correct color perception.
- Paired with the Xybix MyClimate control system, bias lighting can be dimmed, brightened and turned "on/off" with the MyClimate hand controller.



Rollervision®

Rollervision® is patented by Xybix. This focal depth adjustment feature, allows for 6 or more computer monitors to seamlessly glide (at the same time) on ball bearing wheels in a forward and reverse motion, allowing user's effortless adjustment in their monitor focal viewing plane.

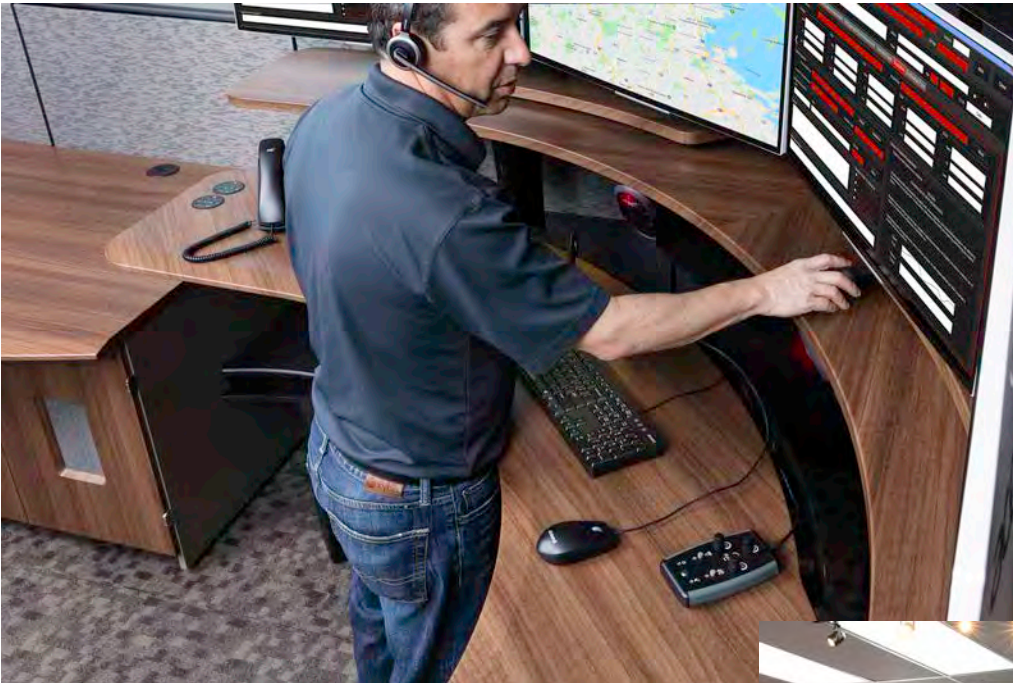

Features

- All monitors move simultaneously to achieve the optimal focal depth for each user.
- Reduces eye strain.
- Easily add and reposition monitors.
- Smooth, whisper-quiet gliding operation.



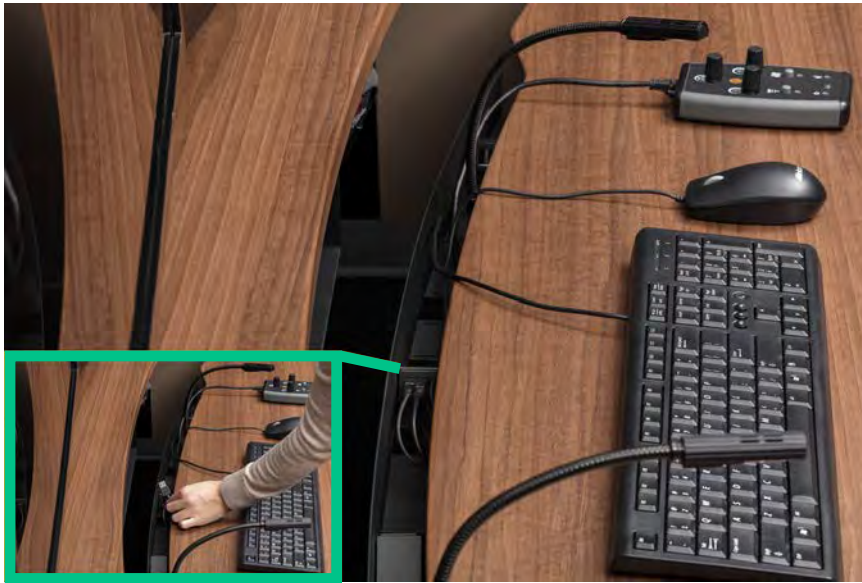

DataDock - Cable Organizer

DataDock is a concealed data connection bay that is located on the back edge of the keyboard surface. DataDock allows for easy access to cables and plug&play connectivity to PC's.

- Configurable for USB, RJ11, RJ45 connections
- Instantly replace keyboards and mice
- Cable organizer tray keeps cables hidden yet accessible.

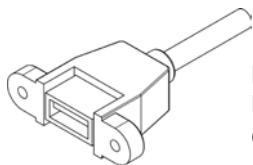

USB Port

Ext Cable USB Type A to Type A Panel Mount for Datadock
(used for multiple computer devices)

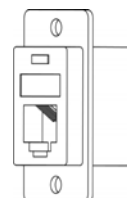

RJ11

Datadock - Panel Mount RJ11 CAT3 Coupler *(used for phone)*

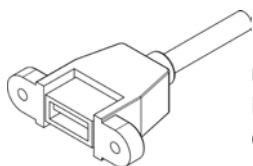

USB Port - Charge Only

USB charge only Type A to Type A Panel Mount for Datadock
(used for multiple computer devices)

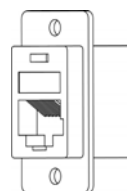

RJ45

Datadock - Panel Mount RJ45 CAT5 Coupler *(used for data)*

Hand Controls

While there are a variety of options available in Xybix's hand controls, most of our current consoles offer a recessed, independent front and rear control. The number displayed on the hand control is worth noting. Users can revert their console back to their desired height setting using this number.

Discussed later in this document will be trouble shooting for hand controls and surface movement.

HAND CONTROL FOR T4, T5, and T6+ TABLES

If your table has four, five, six or more legs, this should be your hand control.



Trouble Shooting for this hand control can be found on page 23.

HAND CONTROL FOR T2 or T3 TABLES

If your table has two or three legs, this should be your hand control.



Trouble Shooting for this hand control can be found on page 28.

Caution:

*If you are having trouble operating your console, i.e. only one side is adjusting. Please **STOP** immediately and see our trouble shooting section.*

MyClimate Control

MyClimate is personal climate control for Xybix’s ergonomic consoles. The MyClimate should be located on the main keyboard surface; it is equipped with a motion activated sensor located on the base of the controller. In order for the hand control to properly work, please ensure that this sensor is facing the user and that there is nothing obstructing the sensor on the lower, front part of the controller.



Air Speed

To adjust the air speed and flow of the MyClimate personal control fan, turn the knob, located on the hand control in a clockwise motion. The further to the right you turn the knob, the higher the airflow.



Filter Maintenance



The MyClimate system is equipped with air filters, similar to car vent filters, which trap and lock dust and debris. From time to time, these filters need to be cleaned and replaced. Xybix has made this easy, with removable filters that can simply be washed.

First, ensure your fan speed is in the "off" position. Remove the blue fiber filter clean by soaking in a warm soapy water mixture for approximately 5min, then rinse with cool water. After the filter is dry, replace the filter as it was found.

Heat Control



To turn "on" or "off" the heat on your console, find the push button that shows three wavy lines, located on the MyClimate hand controller. Simply press this button to turn on the heating feature of your console. Please note, this feature will also turn off if no motion is detected at the console for more than 15min. Heaters can be adjusted to "High" or "Low" by flipping the switch on the bottom of the heater itself.

Lighting Adjustment

Similar to the fan feature, to adjust the lighting at your console, find the two knobs labeled with the small light bulb located on the MyClimate hand controller. You will need to turn these knobs in a clockwise motion. This will dim and brighten your task lighting. The further to the right you turn the knob, the brighter the task light will become. Likewise, the further you turn the knob to the left (counter clockwise), the more dim your lighting will become.



Console Operation

Operating your Xybix console will be easy and effortless.

Xybix consoles offer two separate work surfaces, a front and a rear. The rear surface will contain Rollervision[®], the focal depth adjustment feature, as well as any lighting features attached to the rear arc.

Attached to Rollervision[®] will be your computer monitors (as noted earlier, Rollervision[®] allows 6 or more monitors to be seamlessly adjusted with one simple forward and reverse movement).

Located under your monitors, on the rear work surface will be your MyClimate personal fan. (If applicable this is also where the CPU hangers are located).

The front or keyboard surface, is the work surface closest to the user; this is where your keyboard and mice will be located, as well as the optional data dock, cup holder and hand controls.

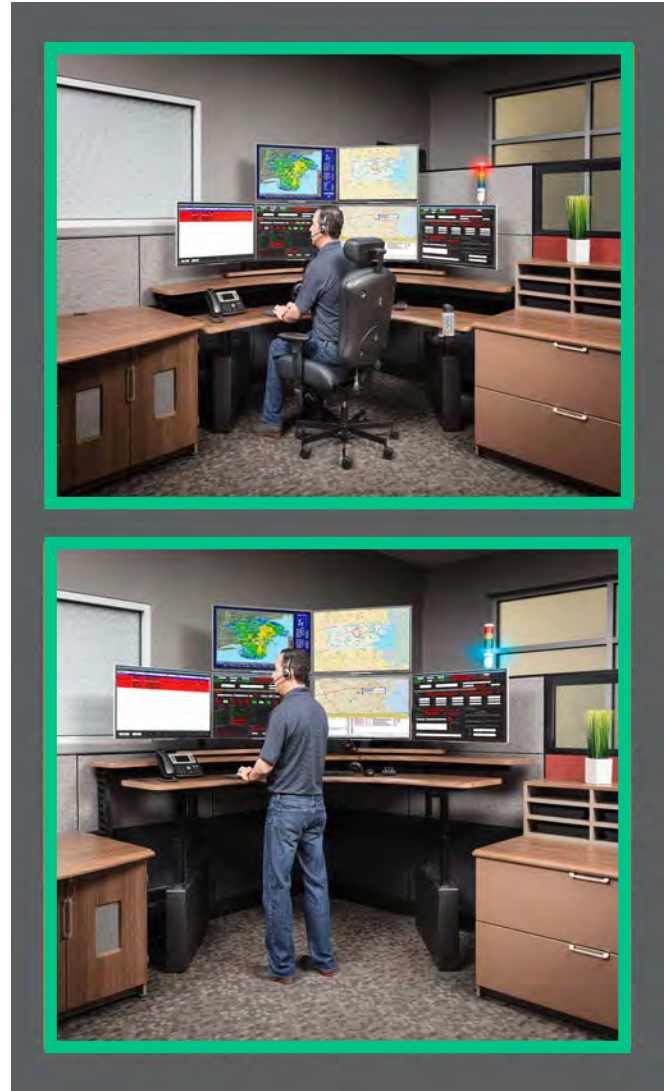

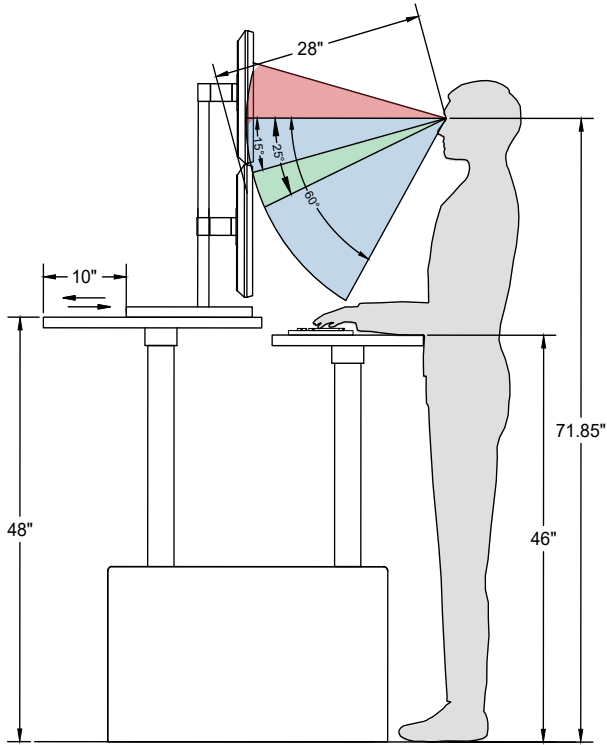

**95TH PERCENTILE MALE (6'-4")
 BASED ON 24" FLAT PANEL MONITORS**

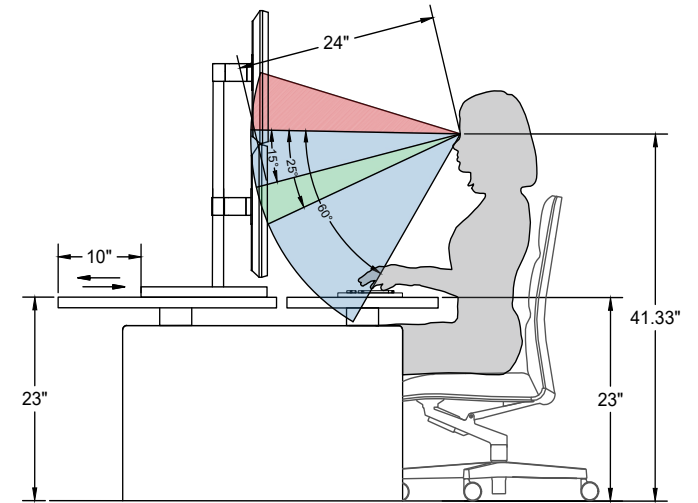

**5TH PERCENTILE FEMALE (4'-11")
 BASED ON 24" FLAT PANEL MONITORS**

- Area above horizontal, poor ergonomics
- 15° - 25° ideal monitor viewing angle, center of screen
- Preferred visual area including keyboard

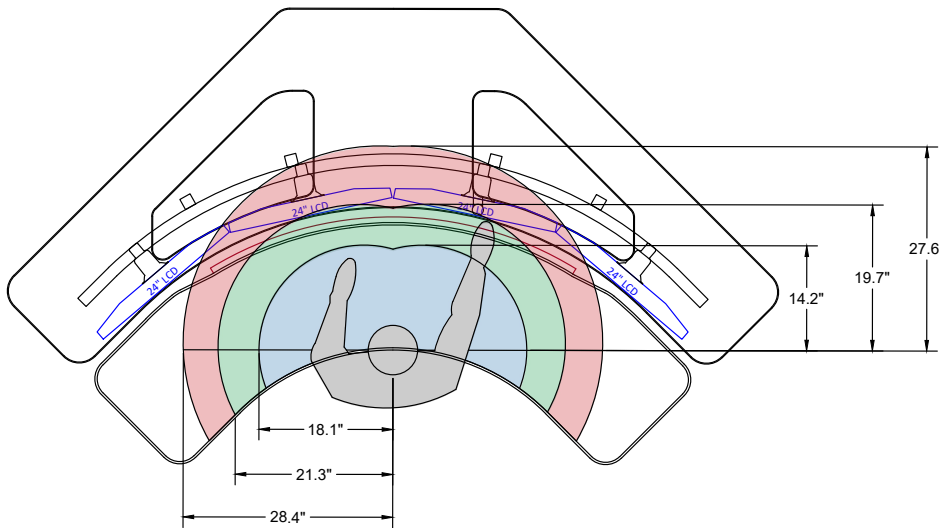
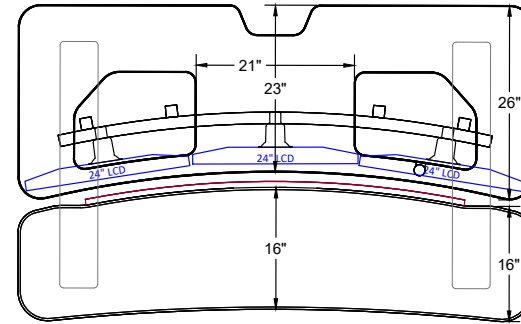
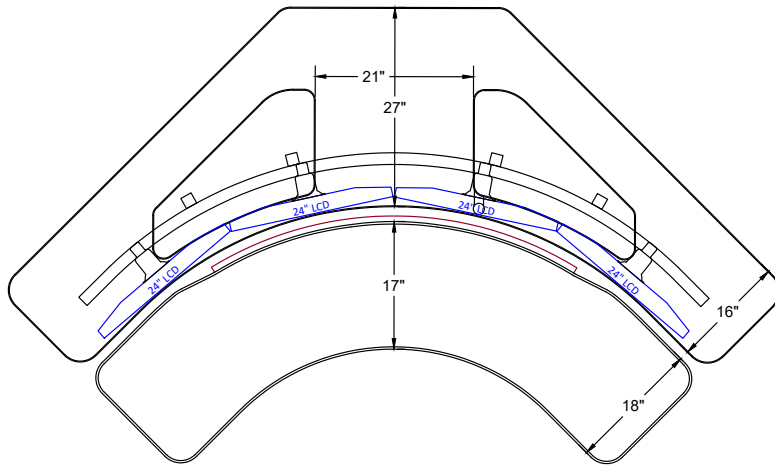

**REACH ZONES FOR
 CORNER WORKSTATION**

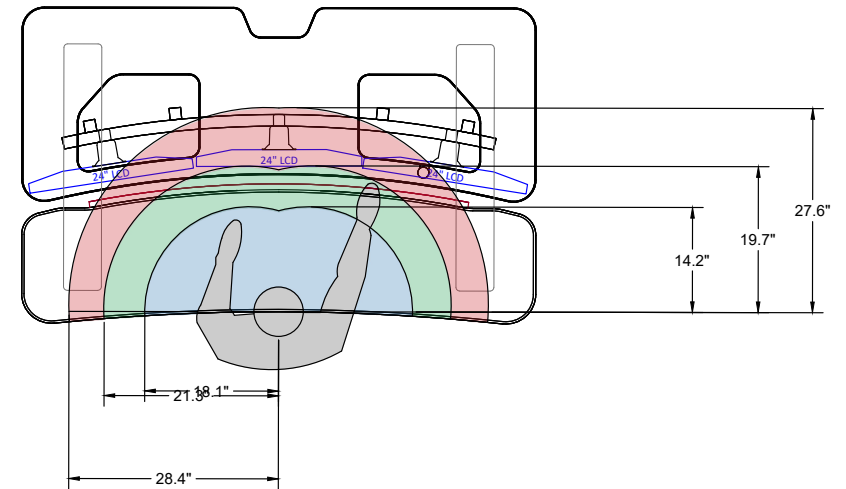

**REACH ZONES FOR
 STRAIGHT WORKSTATION**

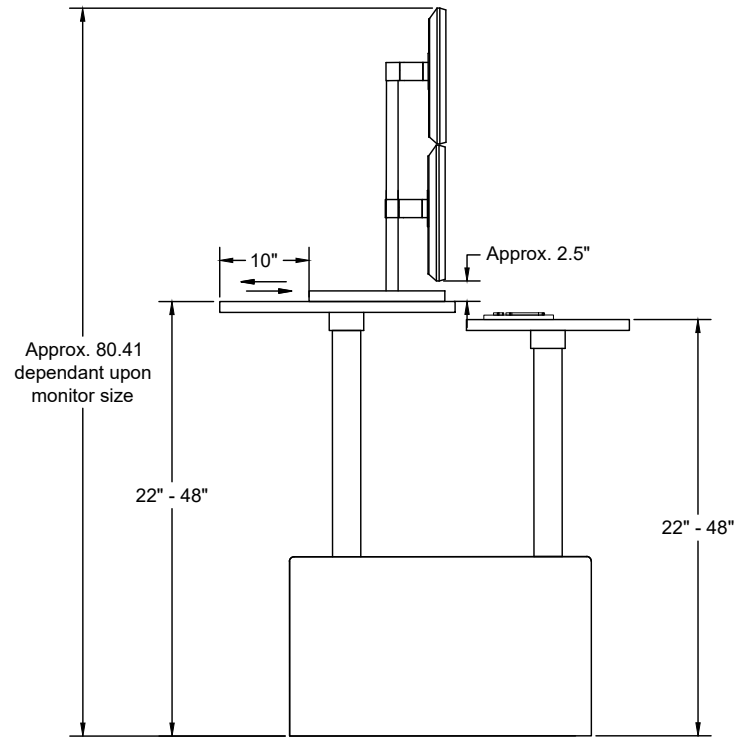

ADJUSTMENT RANGE
BASED ON 24" FLAT PANEL MONITORS

Xybix Consoles have a true sit to stand adjustment range of 22"-48" AFF, or, a total height adjustment range of 26".

Xybix's Rollervision monitor mounting system provides 10" of focal depth adjustment.

Console Obstruction

Before the operation of your console, it is critical that you check to make sure that all areas of movement are clear and there are no obstructions to inhibit movement of your console.

When moving the console downward, areas that most frequently should be checked are under the work surface (trash bins, coats, bags, filing cabinets, etc). Ensure that all cabinet doors are closed and nothing is between the two work surfaces.



When moving the console upward, areas that should be checked are cabinet doors and anything attached to the panel walls (your cubical walls). Check to make sure that any objects on top of the work surface are cleared from area of movement. Check to make sure that nothing is between the two work surfaces.



Console Operation Problems

STOP!!!! If you are having further operating problems with your console, please call Xybix Customer Service at 800.788.2810. Or, visit the Trouble Shooting Section of this guide.

Power Bar

The power bar supplies power to all of your console components. There are usually three power bars per console. Equipment can be plugged into this surge protecting device. Please note there is an "on/off" red toggle switch as well as a reset button on the side of the power bar.

Power bars are installed throughout your console for your convenience.

**For specific power requirements or needs, please contact Xybix directly.*

Reset Button



Energy Chain

The energy chain(s) are located on your rear work surface and will connect to your CPU storage unit. One energy chain will connect from your rear work surface to the Rollervision®, focal depth adjustment technology. The chain linked black cord containment system is used for cable management and will prevent cable cords from being tangled or damaged. This also ensures that the proper cable length is being used to accommodate the adjustable height table.



Easy Access Clips allow you to easily add/change cabling

Simply use a flat-head screwdriver and press and left the clip open.

Trouble Shooting Guide

A More In-Depth View of your Console and Components

In the table base case of your console you will find several parts and features as well as connections. To access your connections, use a 4mm allen's wrench (which you should have been provided).

Under your console you will find several parts that can help you understand more about your new furniture and its features. Let's take a further look!

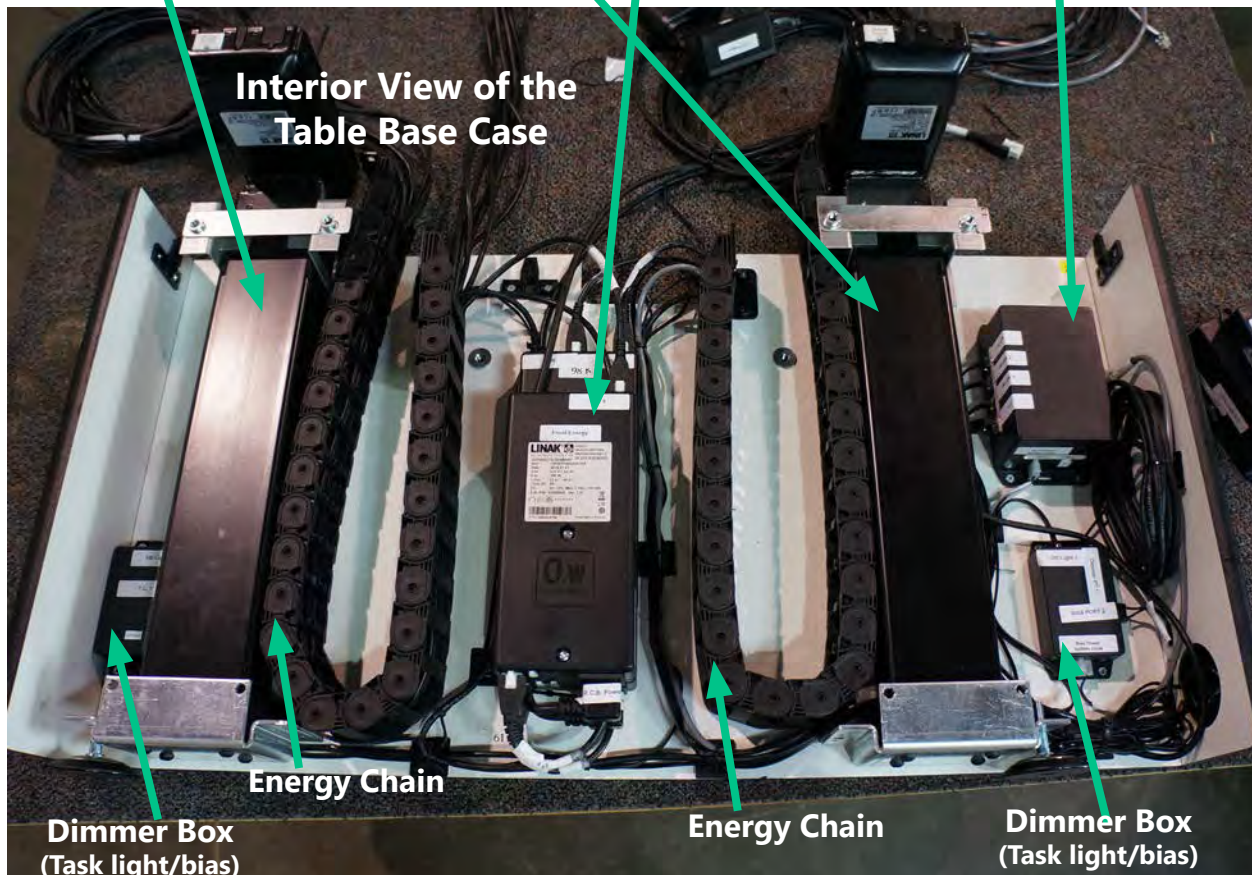
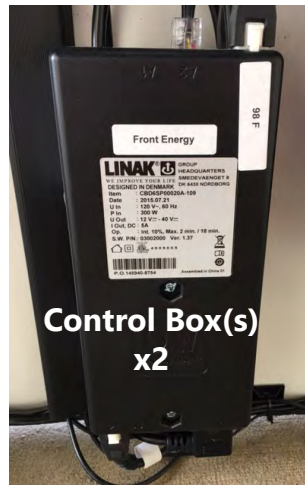
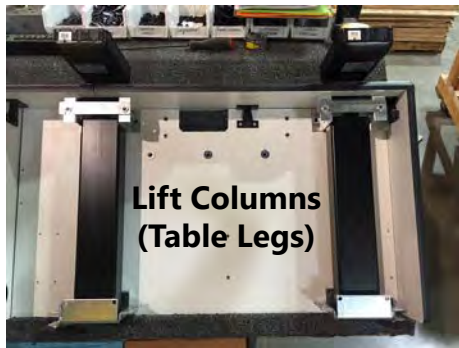

Operations Trouble Shooting Guide

Trouble shooting your console

Hand Control (T4, T5, T6+ and Eagle Tables) (If your table has four, five, six or more legs, this should be your hand control)

Located on top of the work surface Xybix hand controls offer an easy way to operate a dual surface or single surface console.

Hand Controls are used to adjust console height and with a push of a button, can be used in for the seated or standing position.

Procedure for Reset and Initializing:

1. Ensure there are no obstructions which would prevent the desk from moving vertically.
2. Press and hold the "DOWN" arrow button.
3. Continue to hold the "DOWN" arrow button, the desk will lower until it reaches the bottom.
4. The system has now been reset and initialized and the table is now ready for use.

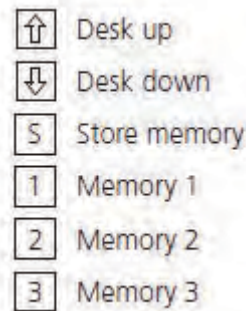

Hand controls with Safety Feature only:

These hand controls have a locking function. When locked, only a bar (-) is shown in the display.

1. Press the "S" button for 2 seconds to unlock. When the hand control is unlocked, the display will show the height. Release the S button.
2. The hand control will be active for 2.5 seconds and the ^ or v keys can now adjust the worksurface.
3. After pressing a key, the control will remain active for another 5 seconds.
4. When no more inputs are made, the hand control will go into locked mode again.

Default Operation:

To run the desk up or down, press the ^ or v keys and keep it pressed until the desk reaches the desired height.

Storing a Memory Position:

1. Move the table to the desired height using the normal operation procedure.
2. Touch the "S" button and the display will flash "S" for 3 seconds.
3. While this is displayed, touch the memory button 1, 2, or 3.
4. The hand control will acknowledge the stored position by flashing S1, S2, or S3 for 1 second.

Moving to a Memory Position:

1. Press a memory key: 1, 2, or 3. The table will move to the desired memory location.
2. Keep pressing the button until the position is reached.

Common Error Codes

Error Code	Problem	Solution
E01	Reset Needed	Perform reset procedure
E16	Too many buttons on hand control pressed simultaneously	Perform reset procedure
E23- E32	Leg or leg cable not connecting	Make sure leg ext cable is plugged in at the top of the leg, and into the control box, inside the black lift case. Perform reset procedure.
E41- E62	Hit obstruction	Remove obstruction from under or between the desks. Perform reset procedure



****PLEASE READ ALL INSTRUCTIONS BEFORE
BEGINNING RESET****

*If only one side is moving, **STOP** trying to reset the work surface and let go of the hand control buttons. Call Xybix Customer Service.*

Reset Instructions

To reset Control Box

1. Turn off power to the power strip that the control boxes are plugged into (on or near the CPU cabinet, if applicable) and keep off for 10 seconds. Turn back on. You can also just unplug the power cords from the black leg box that plugs into the power strip, if you don't turn off the whole power strip at once. Keep unplugged for 10 seconds and then plug back in.
2. Reset the control box by holding the **DOWN** button and the work surface will move down evenly to its bottom. The hand control will show an error code of E01 while the table is resetting. If it was uneven, and **all the legs are moving**, let the table keep going down until it reaches the lowest setting. All the legs should be moving during the reset. Again, **if a leg is not moving at all, STOP the reset by letting go of the hand control.**
3. When the work surface has reached its lowest height, keep holding down the **DOWN** button until the table bounces back up an inch or less (this could take up to 15 seconds). After the table bounces back up, the control box is reset and the work surface will move up and down evenly.
4. If nothing is happening when you try to reset, what do you hear? See troubleshooting chart **on the next page.**

How to level an uneven table

If a table is uneven and one leg is not moving during the reset procedure, STOP PUSHING THE DOWN BUTTON! You will need to contact Xybix Customer Service! However, you can get the table even with the height of the **non-moving leg** while waiting for a technician - **as long as the non-working leg is lower than the working legs.**

You will have to use the 4mm allen's wrench tool to open the table base case which is closest to the CPU cabinet. Remove the screws from the top and then from the front of the box. The legs closest to the black box will be in the control box ports labeled 61R for the rear leg and 61F for the front leg. The legs furthest from the black leg box will be labeled 78R-78F or 84R/84F based on how long the cables are to those legs. You can then unplug the non-working leg cable from the control box. The working leg cable(s) can be plugged into Port 1 of the control box to move it or them **down only** to match the height of the non-working leg. Before closing up the black leg box, make sure the small, metal leg clip is in place. This piece stabilizes the legs. Do not tighten each bolt completely before tightening the next bolt - tighten all bolts a little and then go back and tighten completely.

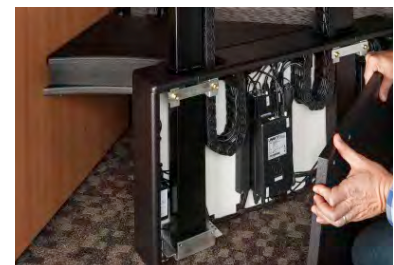
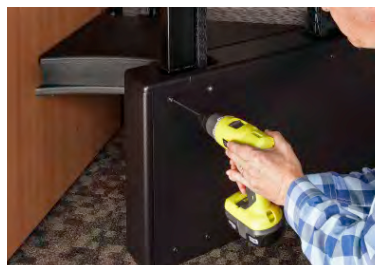

Console Trouble Shooting Graph

	Failure	Questions	Questions	Questions	Solution	Action	Further Action Steps
1	No Display- no power	Is the control box /transformer connected to working power outlet?	Are the leg motor cables properly connected to the control box (Insufficient plug contact)?	Is the hand control connected at the Control Box? When pulling on Hand Controller cable, are the colored wires exposed?	If all connections are good, then unplug from power for minimum 10 sec and re-plug	Reset Control Box according to the Trouble Shooting instructions	Email Customer Service and reference failure line number
2	Hand control beeps when pressing a button	Are the leg motor cables properly connected to the control box (Insufficient plug contact)?	Check for poor connections on Extension Cables		If all connections are good, then unplug from power for minimum 10 sec and replug	Reset Control Box according to the Trouble Shooting instructions	Email Customer Service and reference failure line number
3	Handset shows "E"	Does the work surface move up or down?	When pulling on Hand Controller cable, are the colored wires exposed?		If all connections are good, then unplug from power for minimum 10 sec and replug	Turn power off- open Hand Controller by removing screws- place cable connection in strain relief	Handset still shows "E"Replace handset Email Customer Service and reference failure line number
4	Intermittent hand control operation	Is the hard wired connection to the hand control loose?			If you push the wires towards the hand control and it works this is an internal short.		Replace handset Email Customer Service and reference failure line number
5	Table leans to one side, after/during movement	If solution causes the table to become more out of level- STOP-and contact Customer Service	Is there an obstruction or overload?	Are the leg motor cables properly connected to the control box (Insufficient plug contact)?	If all connections are good, then unplug from power for minimum 10 sec and re-plug	Remove overload/ obstruction -Reset	Email Customer Service and reference failure line number
6	Table moves 2 inches in opposite direction while moving	Are there any obstacles in the movement path?				Remove obstacle	Email Customer Service and reference failure line number

	Failure	Questions	Questions	Questions	Solution	Action	Further Action Steps
7	While resetting, only one leg moves, no function afterwards	If solution causes the table to become more out of level-STOP-and contact Customer Service	Are the leg motor cables properly connected to the control box (Insufficient plug contact)?		If all connections are good, then unplug from power for minimum 10 sec and re-plug	Reset Control Box according to the Trouble Shooting instructions	Email Customer Service and reference failure line number
8	Beep on key-press				If all connections are good, then unplug from power for minimum 10 sec and re-plug	Reset Control Box according to the Trouble Shooting instructions	Email Customer Service and reference failure line number
9	After reset, no movement possible	Are the leg motor cables properly connected to the control box? (Insufficient plug contact)				Reset Control Box according to the Trouble Shooting instructions	Email Customer Service and reference failure line number
10	No reset possible	Is the control box /transformer connected to working power outlet?	Are the leg motor cables properly connected to the control box (Insufficient plug contact)?	Is the hand control connected?	If all connections are good, then unplug from power for minimum 10 sec and re-plug	Reset Control Box according to the Trouble Shooting instructions	Email Customer Service and reference failure line number
11	Legs stop while performing reset procedure	Are the leg motor cables properly connected to the control box? (Insufficient plug contact)				Reset Control Box according to the Trouble Shooting instructions	Email Customer Service and reference failure line number
13	Control Box clicks & Console does not move	Are the leg motor cables properly connected to the control box? (Insufficient plug contact)					

Operations Trouble Shooting Guide

Trouble shooting your console

Hand Control (T2 and T3 Tables) *(If your table has two or three legs, this should be your hand control)*

Located on top of the work surface Xybix hand controls offer an easy way to operate a dual surface or single surface console.

Hand Controls are used to adjust console height and with a push of a button, can be used in for the seated or standing position.



Procedure for Reset and Initializing:

1. Once you have fully assembled your desk. It needs to be initialized at the lowest position.
2. Ensure there are no obstructions which would prevent the desk from moving vertically.
3. Hover your fingers over the "UP and DOWN" arrow buttons at the same time.
4. Continue to hover over the "UP and DOWN" arrow buttons, the desk will lower until it reaches the bottom.
5. Once the system beeps, release the "UP and DOWN" buttons.
 - a. If it does not beep, continue to hover over the buttons for 3 seconds after the desk reaches the lowest point.
6. The system has now been synchronized and the table is now ready for use.

Memory Set Positions:

1. To be performed after "Reset and Initializing".
2. Move the desk to the desired memory position.
3. Press and hold the M button until the display flashes.
4. Repeat for programming positions 2 and 3.

Moving to a memory preset position:

1. Ensure there are no obstructions which would prevent the desk from moving vertically.
2. Press and hold the memory button #
3. The desk will move to the preset position.

TroubleShooting T2, T3

Problem	Observation	Solution
The Legs do not move	<ul style="list-style-type: none"> - Is the power cable connected to the power supply? - Make sure all plugs are mounted correctly into the control box and legs. - One or more legs/cables are defective - Look for visible damages on cables, control box, and legs. 	<ul style="list-style-type: none"> - Connect power - Check all connections - Perform reset and move table upwards. If table will not move upwards after reset, it is defective. - Contact Xybix customer service at the number below.
The table tilts or moves incorrectly	<ul style="list-style-type: none"> - Visually identified 	<ul style="list-style-type: none"> - Perform reset
The table stops and can only move downward	<ul style="list-style-type: none"> - Is the table at the highest position? - Table could be overloaded 	<ul style="list-style-type: none"> - When the frame has reached the max height, it will only move downwards. - Remove some items from the table and try again
Table always stops at the same position, before max height	<ul style="list-style-type: none"> - Has the system been programmed to this specific height? 	<ul style="list-style-type: none"> - Perform reset
Not all legs move at the same time or at the same speed	<ul style="list-style-type: none"> - The immobile or slow leg could be defective 	<ul style="list-style-type: none"> - Check connections and perform reset. If this does not work, leg may need to be replaced. Contact customer service at the number below.



axys QUICK START GUIDE

This Xybix desk is equipped with our Axys control system. It allows you to control desk functions like desk height, lighting color/intensity, fans, and temperature via a Windows PC*, Apple iOS device, or Google Android device.

Follow these steps to begin using the Axys system:

1. Choose the device(s) to control the system

You can connect a single Windows 10 or 11 PC (wired, via a USB cable) and an unlimited number of iOS and Android devices wirelessly via Bluetooth.

2. Download the Axys software for your devices

The Windows app can be found at www.xybix.com/axys. The iOS and Android apps can be found in the Apple or Google Play stores by searching for "Xybix Axys." You can also scan the QR codes on the back of this guide to access the apps directly from your devices.

3. Run the Axys software app on your devices

The Axys software should automatically detect the features installed in your Xybix desk and allow you to control them via the app. Different users can create their own accounts and save an unlimited number of their favorite settings combinations, known as "scenes." Detailed instructions, tutorial videos, and troubleshooting information for the Axys control system can be found at www.xybix.com/axys-support.

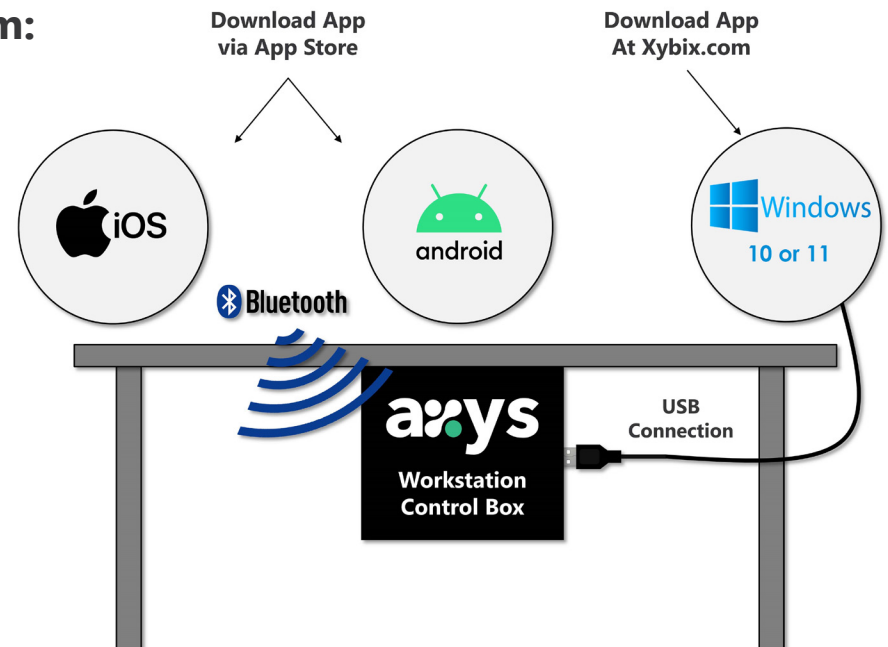

* The Windows application software requires Windows 10 or 11. Windows XP, Vista, 7, 8, and 8.1 are not currently supported

USING THE **axys** APPLICATION SOFTWARE

Scenes & Desk Settings

Easily create and access your scenes or connect to different AxyS-enabled desks.

Task Lighting Controls

Toggle task lighting with the tile button and adjust brightness with the slider.

Desk Height Controls

Toggle sitting or standing with the tile button and adjust heights with sliders.

Heating Controls

Quickly enable your desk's heaters with the heater tile button.

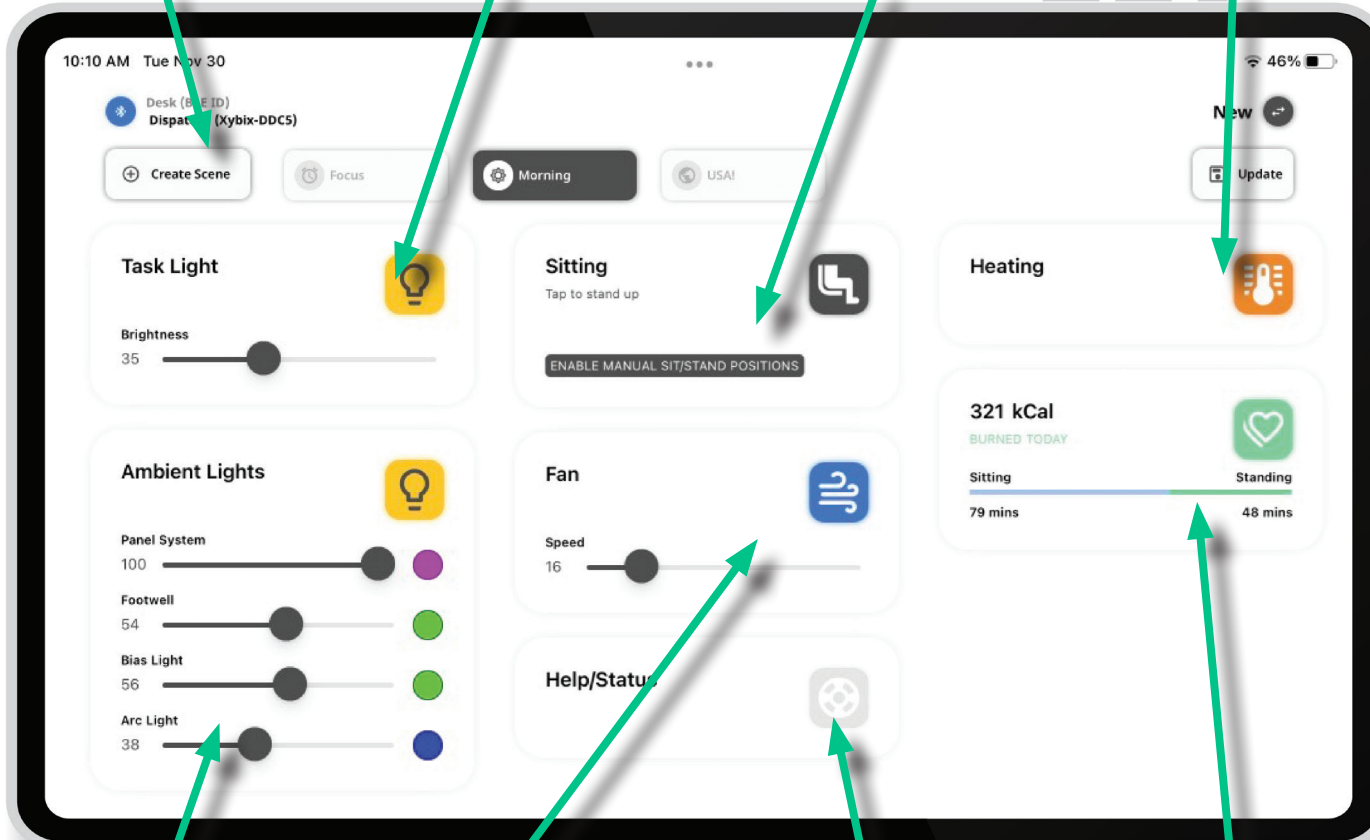

Ambient Lighting Controls

Toggle or change colors with the tile buttons and adjust brightness with the sliders.

Air Flow Controls

Toggle your desk's fan with the tile button and adjust the intensity with the slider.

Help/Status Light Controls

Instantly toggle your desk's status light with the help/status tile button.

Calorie Counter (Optional)

Measure calories burned for sitting or standing users with the calorie counter tile button.

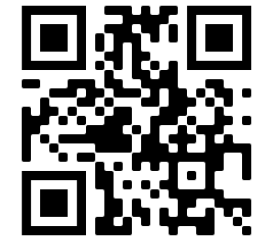

Windows
Download



Apple iOS
Download



Android
Download

CERTIFICATE OF COMPLIANCE



Xybix Systems Inc.

Xybix ErgoPower® Electric Height Adjustable Workstations and Consoles

9688-410

Certificate Number

12/02/2009 - 12/02/2022

Certificate Period

Certified

Status

UL 2818 - 2013 Standard for Chemical Emissions for Building Materials, Finishes and Furnishings

Commercial furniture and furnishings are tested in accordance with ANSI/BIFMA M7.1-2011(R2016) and determined to comply with ANSI/BIFMA X7.1-2011(R2016) and ANSI/BIFMA e3-2019 Credit 7.6.1 in an Open Plan Office and Private Office environment.

Products tested in accordance with UL 2821 test method to show compliance to emission limits in UL 2818, Section 7.1.



UL investigated representative samples of the identified Product(s) to the identified Standard(s) or other requirements in accordance with the agreements and any applicable program service terms in place between UL and the Certificate Holder (collectively "Agreement"). The Certificate Holder is authorized to use the UL Mark for the identified Product(s) manufactured at the production site(s) covered by the UL Test Report, in accordance with the terms of the Agreement. This Certificate is valid for the identified dates unless there is non-compliance with the Agreement.

GREENGUARD Certification Criteria for Furniture and Mattresses

Criteria	CAS Number	Maximum Allowable Predicted Concentration	Units
TVOC _(A)	-	0.50	mg/m ³
Formaldehyde	50-00-0	61.3 (50 ppb)	μg/m ³
Total Aldehydes _(B)	-	0.10	ppm
4-Phenylcyclohexene	4994-16-5	6.5	μg/m ³
Individual VOCs _(C)	-	1/10th TLV	-

- (A) Defined to be the total response of measured VOCs falling within the C₆ – C₁₆ range, with responses calibrated to a toluene surrogate.
- (B) The sum of all measured normal aldehydes from formaldehyde through nonanal, plus benzaldehyde, individually calibrated to a compound specific standard. Heptanal through nonanal are measured via TD/GC/MS analysis and the remaining aldehydes are measured using HPLC/UV analysis.
- (C) Allowable levels for chemicals not listed are derived from 1/10th of the Threshold Limit Value (TLV) industrial work place standard (Reference: American Conference of Government Industrial Hygienists, 6500 Glenway, Building D-7, and Cincinnati, OH 45211-4438).





10-YEAR PREMIER PLUS WARRANTY

Xybix is committed to keeping your 24/7 mission-critical workstations at the ready.

10 Years: Everything. Parts, shipping, labor, everything.

Lifetime: Parts manufactured by Xybix will be warrantied for life. Labor and shipping is included in the first 10 years.

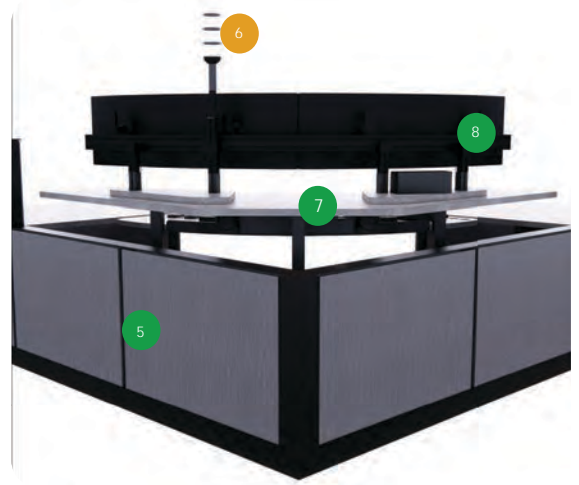
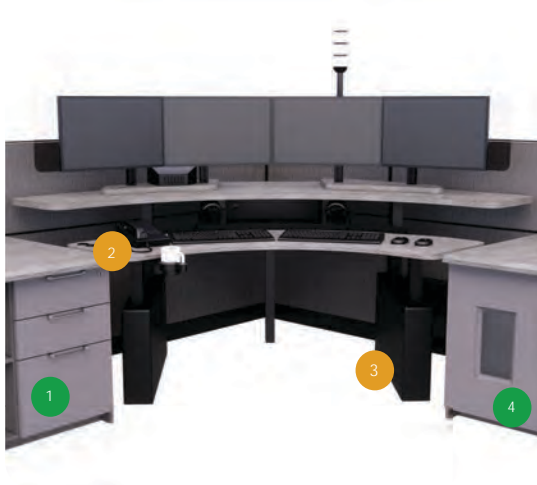

Items in **GREEN** are guaranteed for the lifetime of the item.

Items in **ORANGE** are guaranteed for 10 years.

- 1
- 2
- 3
- 4

Door/Drawer Fronts
Climate Control
Lift Motors
Cabinet Materials

- 5
- 6
- 7
- 8

Panel Frame and Surfaces
Status Indicator Lights
3D Laminate Work Surfaces
RollerVision™

Premier Service: For a timely warranty solution, the Buyer will cooperate with the Xybix Customer Service Team. With guidance from Xybix, the Buyer agrees to perform basic troubleshooting tasks to determine the nature of the problem and to self-correct before on-site assistance can be provided. For simple replacements, Xybix will promptly ship parts to the Buyer.

Xybix will provide personnel for components that require on-site repair. These repairs will be performed during normal work hours as scheduled by the Xybix Customer Service Team. For repairs that have resulted from circumstances outside the warranty coverage, and/or the Buyer imposes conditions or restrictions that increase repair costs, the Buyer agrees to reimburse Xybix for resulting additional expenses. The Buyer agrees to dispose of old parts and packing materials.

This warranty is for new purchases only and would not apply to circumstances that include normal wear and tear, damage, misuse, power surges, modifications, consumable items, mobile/tablet devices or software, or products shipped outside the United States.

Any repairs, substitute products, or replacements of equal or higher value used to resolve a warranty claim will in no way extend the applicable warranty period applied to the original product. Product repair or replacement is the Buyer's exclusive remedy for all warranty solutions covered under this non-transferable warranty. Xybix makes no other express or implied warranties to any product except as stated above.

Xybix Systems, Workstation Warranty

XYBIX SYSTEMS WORKSTATIONS 10-YEAR PREMIER PLUS WARRANTY

Warranty Terms and Conditions

Defects in Xybix manufactured products and components covered by this warranty and found during the applicable *Warranty Period* (see below) will be repaired or replaced (at Xybix's sole option) upon prompt notice from the original buyer. Troubleshooting tasks (as outlined in the *Buyer's Responsibility* below) must be performed before product repair or replacement will be provided.

Warranty Period

Xybix 10-Year Premier Plus Warranty covers all parts, shipping, and labor for 10 years. The 10-year coverage includes parts both manufactured and supplied by Xybix. Parts manufactured by Xybix are warranted for life. The lifetime coverage includes frame, panel surfaces, 3D laminate work surfaces, RollerVision monitor controls, cabinet materials, door/drawer fronts. Labor and shipping for Xybix-manufactured parts is included in the first 10 years. Any repairs, substitute products, or replacements of equal or higher value used to resolve a warranty claim will in no way extend the applicable warranty period applied to the original product.

Warranty Exclusions

- Normal wear and tear
- Consumable items such as light bulbs
- Mobile/table devices or software
- Matching of color, grain, or texture
- Any account not paid in full
- Products that have been:
 - Subject to unauthorized modifications or reconfiguration
 - Subject to improper use or conditions, including negligence, accident, or alterations
 - Damaged by AC power disturbances
 - Shipped outside the United States

Buyer's Responsibility

With guidance from the Xybix Customer Service Team, the Buyer agrees to perform basic troubleshooting tasks to determine the nature of the problem and to self-correct before on-site assistance can be provided. For simple replacements, Xybix will promptly ship parts to the Buyer.

Xybix will provide personnel for components that require on-site repair. These repairs will be performed during normal work hours as scheduled by the Xybix Customer Service Team. For repairs that have resulted from circumstances outside the warranty coverage, and/or the Buyer imposes conditions or restrictions that increase repair costs, the Buyer agrees to reimburse Xybix for resulting additional expenses. Expenses include, but are not limited to: parts, shipping, labor, transportation, and accommodations. The Buyer agrees to dispose of old parts and packing materials.

Product repair or replacement is the Buyer's exclusive remedy for all warranty solutions covered under this non-transferable warranty. Xybix makes no other express or implied warranties to any product except as stated above.

Date installed and accepted: _____ Installation performed by: _____

Buyer approval: _____

Buyer printed name: _____

Client name: _____

Xybix SO #: _____ Opportunity #: _____

Revised 4/27/2022



Cleaning Your Investment

You are likely in an active and busy, 24/7 environment. This amount of constant activity typically includes cleaning all or part of your furniture. Regular surface cleaning can help extend the life of your furniture, keep your furniture looking new and help reduce the spread of germs and viruses.

Here are the suggested surface cleaning instructions to help care for your furniture.

Cleaning Common Surface Areas:

- Cabinet doors & drawer fronts
- Desks & furniture components
- Storage fixtures
- Table tops

STAIN RESISTANCE** (See NEMA LD 3-2005 for full description.)	Staining Agent	Required Cleaning Step to Remove Stain	
		Printed	Solid
Cleaning Step Description (In order of use)	Distilled Water	0	0
	Ethyl Alcohol / Water	0	0
	Acetone	5	5
0 - Removed with water	Household Ammonia	0	0
	Citric Acid 10%	0	0
1- 25 cycles spray cleaner or sponge	Vegetable Oil	0	0
	Coffee	0	0
2 - 25 cycles baking soda plus spray cleaner on brush	Tea	0	0
	Tomato Ketchup	0	0
3 - Acetone and cotton ball	Mustard	0	3
	10% Iodine	0	2
4 - Bleach plus cotton ball	Black Permanent Marker	2	0
	#2 Pencil	2	2
5 - Not removed	Wax Crayon	2	2
	Black Shoe Polish	2	2
	Total NEMA Cleanability Score	13	17

Cleaning 3D Laminate

CLEANABILITY

Easy clean-up – usually with just soap and water. Can be safely cleaned and disinfected with many cleaners and disinfectants.

Visit: www.omnova.com/products/laminates/surfx.aspx for additional information.

Cleaning Your Panels and Upholstery

Xybix recommends Crypton Upholstery Cleaners from CF Stinson. They are effective on fabrics that are normally considered dry clean only and are water-based, pH neutral, biodegradable and easy to use. These unique upholstery cleaners do not contain bleach, solvents or harsh chemicals.



Gold Upholstery Stain Remover

Designed to help remove food and beverage stains such as beer, wine, milk and powerful enough to help remove more difficult stains such as blood, mildew, urine and vomit.



Purple Upholstery Stain Remover

Designed to help remove grease, oil, tar, shoe polish, butter, cosmetics, crayon, gum, lipstick and more from all fabrics with a W or WS cleaning code.



Upholstery Disinfectant & Deodorizer

Designed to safely and effectively remove odors while refreshing the fabric surface. Note: When used in conjunction with Crypton fabrics, this product is an EPA registered, hospital-grade quaternary disinfectant.



Upholstery Care Brush

Soft fibred brush to assist with cleaning.



Ruby Extractor Machine

Compact and powerful, Ruby was specifically designed for upholstery and spot cleaning of carpets. Ruby features a 1 HP vacuum motor that creates cyclonic action to help rinse away stains. The clear view hand tool makes it easy to see stains as they are vacuumed away.

Crypton cleaners can be ordered from amazon.com or directly from CF Stinson at 800.841.6279

How Do I Disinfect My Xybix Workstation?

Our family at Xybix Systems, Inc. values the health and safety of our loyal customers. We are working diligently to answer accurately and thoroughly your many questions about COVID-19 as it relates to your Xybix products.

Following are answers to your top questions about cleaning your Xybix workstation to prevent the spread of COVID-19 and other viruses.



1. How can I effectively and safely disinfect the panel systems, HPL (high-pressure laminate) OR 3D Laminate desktop of my workstation?

The following cleaning products and those similar to them are effective for cleaning panel top caps, 3D laminate, and HPL (high-pressure laminate)—with no damage to surfaces:

- Lysol Brand Disinfectant® wipes and sprays – non-bleach/non-ammonia types
- Clorox Healthcare® Hydrogen Peroxide Cleaner Disinfectants – non-bleach types
- Formula 409™



2. How do I avoid damaging the surface of my HPL or 3D Laminate workstations?

- Do not use products containing ammonia or bleach. Prolonged exposure of these substances on the laminate or powder-coated surface may cause discoloration and damage your product.
- Do not use acidic or abrasive cleaners.
- Do not use abrasive pads.

The EPA compiled [this list](#) through its Emerging Viral Pathogen program, by which manufacturers provide the EPA with data that proves their products are “effective against harder-to-kill viruses.” HOWEVER, it is likely that many of the listed cleaning solutions contain bleach or other active ingredients that may damage your Xybix products and surfaces, which can nullify your desktop warranty. Use caution when selecting a product for your cleaning or disinfecting purposes.

4. What happens if a cleaning product damages my work surface? Is it covered by my Xybix warranty?

Your Xybix limited lifetime warranty covers the work surfaces and cabinet surfaces: components manufactured by Xybix. Warranty does not cover user abuse or negligence. Improper use of a cleaning product on these surfaces is not covered by your warranty.

5. What products can I safely use if I have an older Xybix workstation with HPL (high-pressure laminate)? It is safe to use the following products on your older HPL (high-pressure laminate) workstation:

- Lysol Brand Disinfectant® wipes and sprays – non-bleach/non-ammonia types
- Clorox Healthcare® Hydrogen Peroxide Cleaner Disinfectants – non-bleach types
- Formula 409™

6. What is the proper technique for cleaning my Xybix workstation?

In addition to using the right cleaning products to clean and disinfect your Xybix products, it’s important to use the right technique to kill germs.

Following are best practices:

- Clean and wipe down all counters in and around the console.
- Clean and disinfect all high-touch areas.
- Clean and disinfect all peripherals including keyboards, mice, phone and input surfaces.
- Clean and disinfect all door handles and drawer fronts.
- Allow the disinfectant to remain wet on the surface until it dries (1-4 minutes on average).

7. Who do I call if I have additional questions related to disinfecting my workstation?

Our Customer Service team at Xybix is here to answer your questions at 800-788-2810.